

Galileo Plus

Mist Collector



Galileo Plus

Galileo Plus is a patented centrifugal filter for mist generated from neat oil and emulsions used in machine tools, also suitable in the presence of particulate.

Galileo Plus is available in 5 models with throughputs from 325 to 3.500 m³/h.

PATENTED



GP 250



GP 500



GP 1000



GP 2000



GP 3000



LOSMA grants that every single system is tested through strict control procedures.

Every unit is provided with a qualitative and functional test certificate.

Working principles

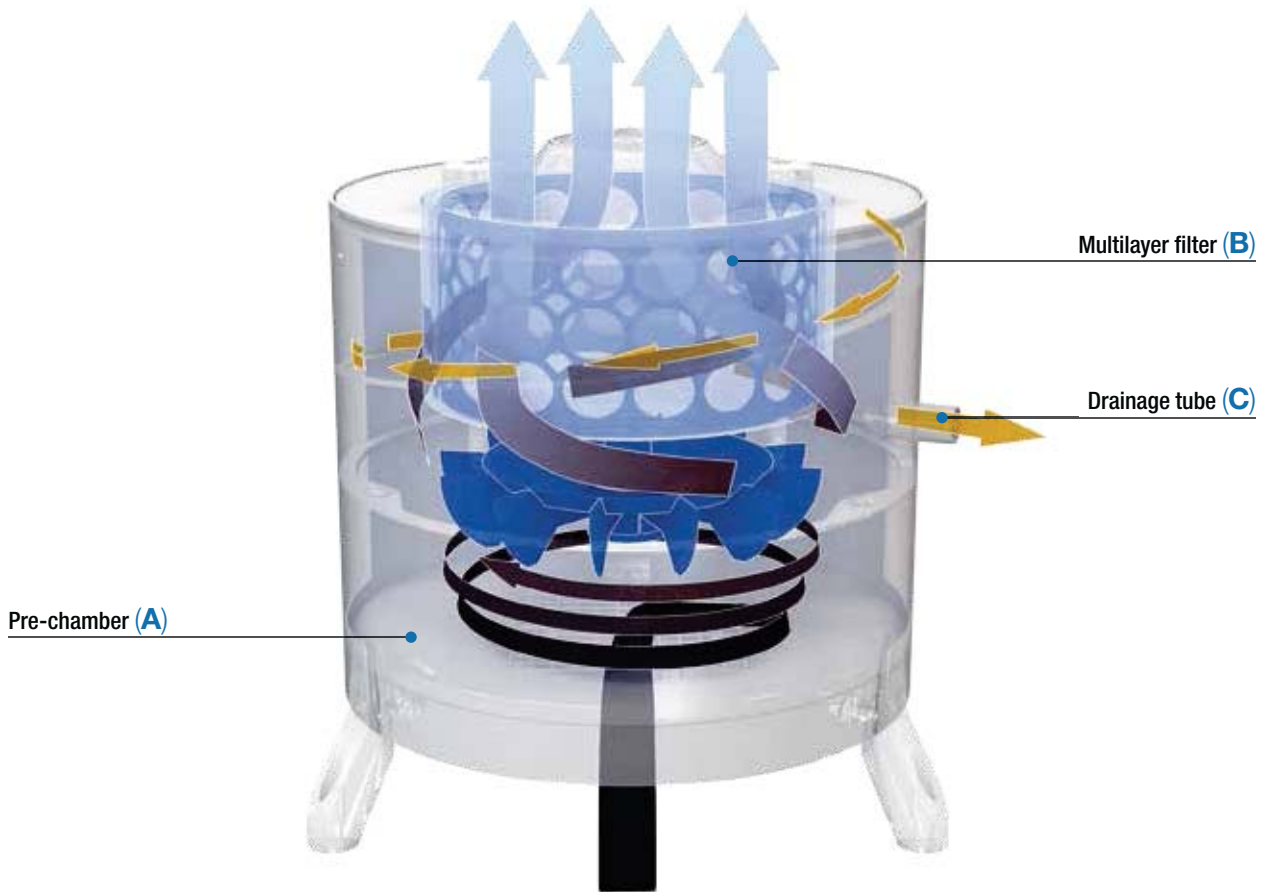

- 1** Polluted air is drawn from machine tool into the lower pre-chamber (A) of Galileo Plus.
- 2** The acceleration effect, due to the centrifugal force generated by a rotating turbine, makes the oil particles bind together and return to liquid state, using the coalescence principle.
- 3** A special Multilayer filter (B) having high filtration efficiency, stops and catches even the smallest pollutant particles, avoiding their dispersion in environment.
- 4** Thanks to a special drainage tube (C) the liquid oil is sent back to the machine tool, to be re-used in working process.

Filter Series



Plus



HIGH FILTRATION LEVEL AND LONG LASTING FILTERS

The combination of the turbine centrifugal action and a high efficiency multilayer filter set guarantees a high filtration level. Filters are positioned after the centrifugal action of the turbine, thus they are exposed to a limited amount of polluting agents, having a small size. This location grants Galileo Plus's filters a longer life than the one of the most common centrifugal or static filters in the market.



REDUCED ELECTRICAL CONSUMPTION

Inspired to Blue Philosophy, Galileo Plus uses energy saving motors with high efficiency and very low power (KW) (see table at next page).



TESTED MATERIAL FROM LOSMA'S LABORATORIES

Galileo Plus internal materials passed compatibility stress tests, carried on with different types of neat oils and emulsions in the market.

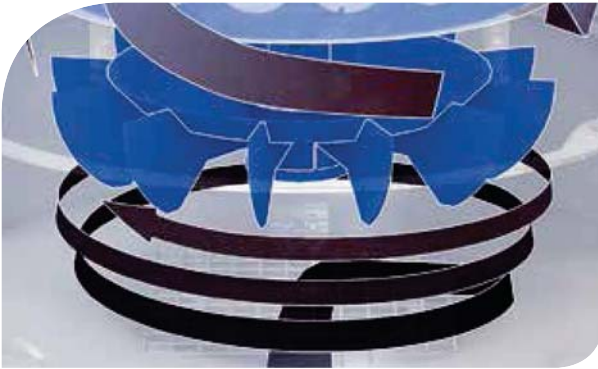

SPECIAL TURBINE

Designed for avoiding dust settlement on its surface, secures no vibrations also in case of big quantities of particulate.



QUICK AND EASY MAINTENANCE

Internal filters can be cleaned or changed simple opening of a cover.



INNOVATIVE DESIGN

Galileo Plus combines the Italian design with cutting-edge technologies for a better working environment.

Optional

G-Clipper Plus

Post-filter cartridge for micro-mist, smoke and vapor. It allows to reach a high filtration level up to 99.97%.

G-Guard

Pre-filtration module useful to optimize air filtration efficiency, in case of high production of oil mist containing dust or swarf chips, also with high pressures. The G-Guard is washable.



Installations



Technical data

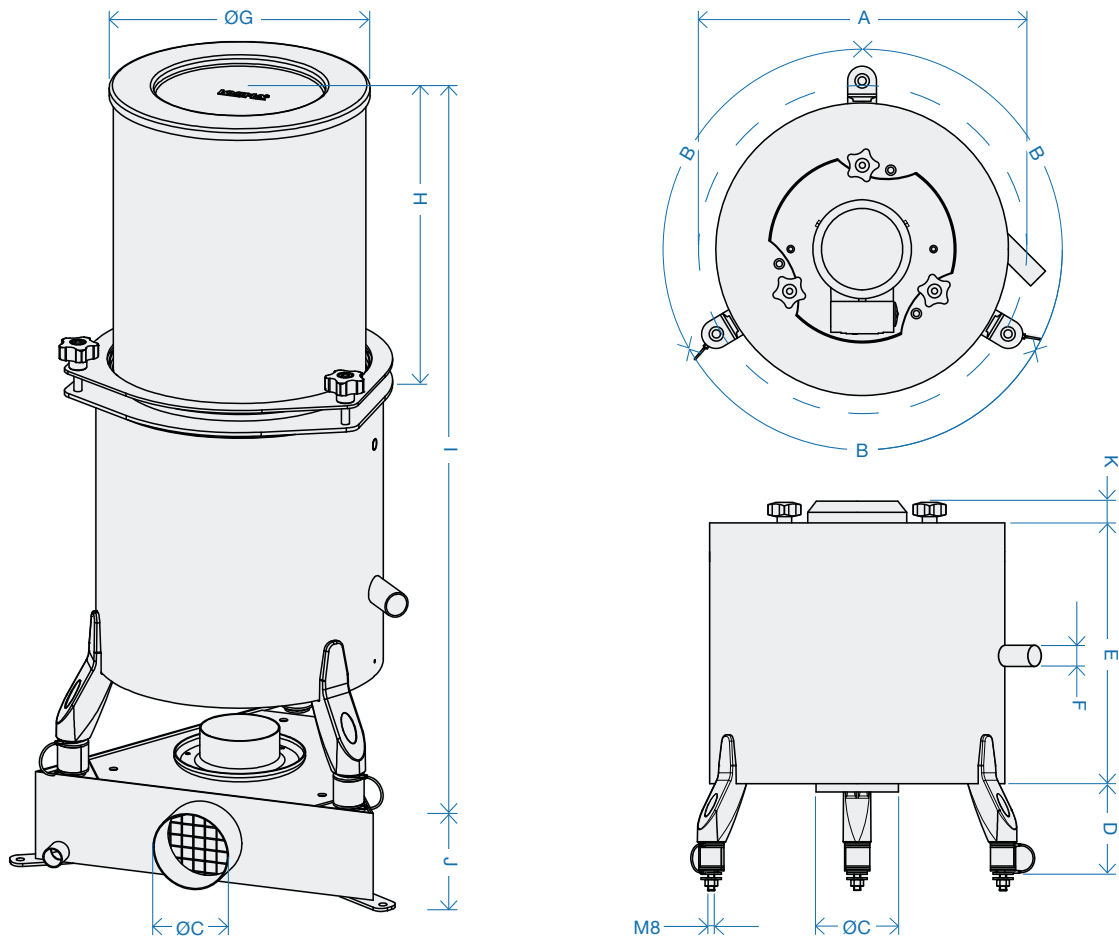

MODELS	Dimensions (mm)					
	ØA	$\langle B$	ØC	D	E	ØF
GP 250	330	120	78	98	388	25
GP 500	400	120	98	98	418	25
GP 1000	490	120	148	88	508	25
GP 2000	530	120	148	88	558	25
GP 3000	560	90	198	88	658	25

MODELS	Dimensions (mm)					
	ØC	ØG	H	I	J	K
GP 250	78	254	314	698	93	22
GP 500	98	315	314	731,5	113	26
GP 1000	148	380	435	940	163	75
GP 2000	148	380	435	990	163	33
GP 3000	198	460	350	1024	218	24,6

MODELS	Flow Rate* (m³/h)		Pressure (Pa)		Power		Ø Inlet (mm)	Noise level (dBA)		Net Weight (kg)
	50 (Hz)	60 (Hz)	50 (Hz)	60 (Hz)	50 (Hz)	60 (Hz)		50 (Hz)	60 (Hz)	
GP 250	325	450	320	410	0,09	0,12	80	58	60	10
GP 500	700	850	800	900	0,25	0,29	100	68	69	14
GP 1000	1520	1550	1000	1210	0,55	0,63	150	70	71	29
GP 2000	2160	2230	1100	1310	1,1	1,3	150	72	73	34
GP 3000	3400	3500	1300	1500	1,5	1,75	200	71	75	54

*Free inlet.



Health



Savings



Efficiency



Environment



Safety



Losma SpA - Via E. Fermi, 16
24035 Curno (BG) - Italia
Cap.Soc. I.V. Euro 500.000,00
Reg. imp. e P.IVA e C.F. 01234590162
R.E.A. 185685



ISO 9001
TUV SUD
Certified
Company



ISO 14001
TUV SUD
Certified
Company



Autorizzato
all'utilizzo



Losma Engineering - Torino
www.losma.it



Germany - Losma GmbH
www.losma.de



USA - Losma Inc
www.losma.com



UK - Losma UK Limited
www.losma.co.uk



India - Losma India Pvt Ltd
www.losma.co.in



斯特莱 (天津) 机械技术有限公司
Stellar (Tianjin) Mechanical Technology Ltd.

Add.: 天津市和平区蒙古路1号
Tel.: 022-8453 6768, 137 8898 6894
138 2182 9836, 186 2253 5816
Fax: 022-84197118
E-mail: info@stellar-mt.com
Web.: www.stellar-mt.com



网址



联系方式

LOSMA中文网址: www.stellar-mt.com
LOSMA英文网址: www.losma.com