

NT-RC

QUICK JAW CHANGE
Tongue & groove

NT-RD

QUICK JAW CHANGE
serrated master jaws

Quick jaw change high precision power chucks

Ø 170 - 400 mm

- centrifugal force compensation
- proofline® chucks = fully sealed – low maintenance
- 3 jaws, closed center

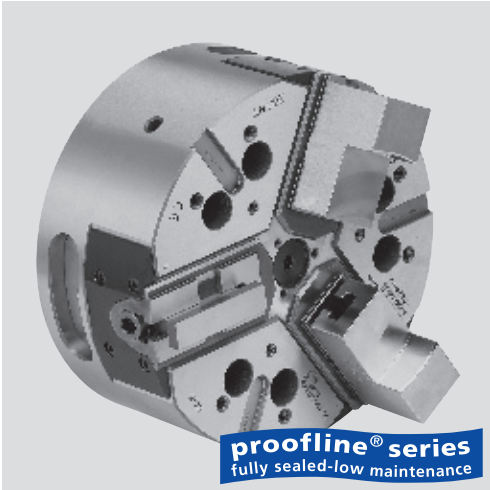

Application/customer benefits

- For mid to large batches flexible production/high speed machining and for fragile parts
- Quick jaw change = short set up time
- Fully sealed, ideal for dry machining of castings and forgings or if high pressure coolant is used
- Ideal for vertical, pick up and horizontal machines

NT-RC: quick jaw change with tongue & groove master jaws

NT-RD: quick jaw change with serrated master jaws (2.5 mm x 60°) (radially adjustable)

Technical features

- High accuracy patented quick jaw change
- Centrifugal force compensation
- Constant gripping force with permanent grease lubrication
- Central bore for coolant and/or air
- Chuck body and internal parts case hardened
- **proofline® chucks** = fully sealed – low maintenance

Standard equipment

- 3 jaw chuck
- 1 set soft top jaws
- 1 quick jaw change wrench
- mounting bolts

Ordering example

- 3 jaw chuck NT-RC 215/A6
- or
- 3 jaw chuck NT-RD 260/FL220

Actual gripping force diagrams

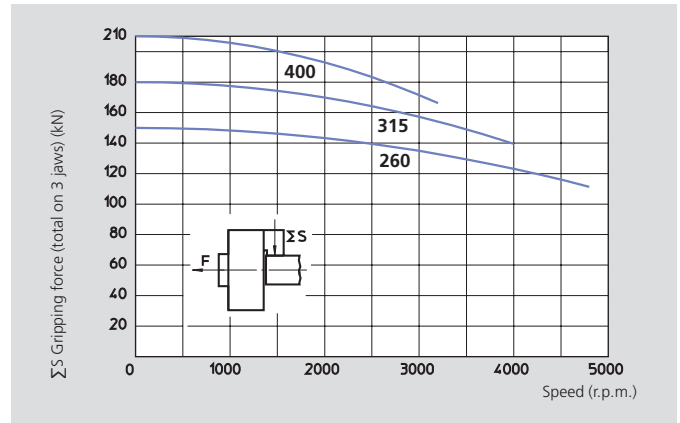
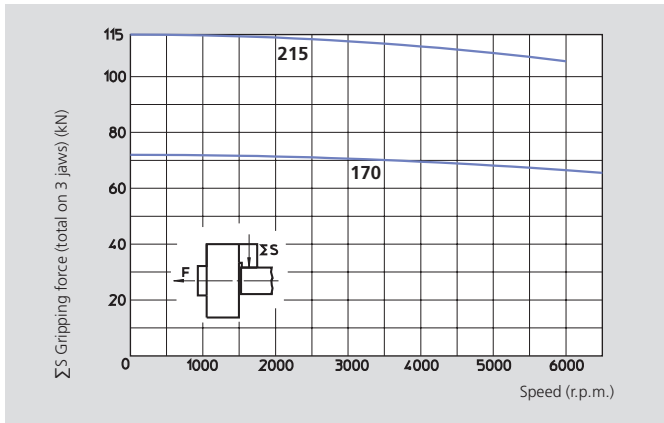

The data in the diagrams refer to 3-jaw-chucks, newly maintained according to their service manuals using SMW-AUTOBLOK K67 grease. The static and dynamic gripping forces have been measured using standard soft top jaws, placed in a position not exceeding the outer diameter of the chuck.

△ Safety advice/danger of damage:

When using taller/heavier jaws and/or clamping on a bigger diameter reduce draw pull/rotating speed accordingly.

Technical data

SMW-AUTOBLOK Type		NT-RD 170 NT-RC 170	NT-RD 215 NT-RC 215	NT-RD 260 NT-RC 260	NT-RD 315 NT-RC 315	NT-RD 400 NT-RC 400
Number of jaws		3	3	3	3	3
Radial jaw stroke	mm	3.6	4.6	5	6.3	7
Axial piston stroke	mm	17	22	24	30	33
Max. draw-pull*	kN	30	42	55	65	75
Max. gripping force*	kN	72	112	150	180	210
Max. speed	r.p.m.	6500	6000	4800	4000	3200
Weight (without top jaws)	kg	13	25	40	68	112
Moment of inertia	kg·m ²	0.048	0.146	0.34	0.84	2.15
Recommended actuating cylinders		SIN-S 100	SIN-S 100/125	SIN-S 125/150	SIN-S 125/150	SIN-S 150/175

* For internal clamping reduce the draw pull by 30 %



Page 324

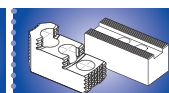

Page 110



Page 225

Quick jaw change high precision power chucks

Ø 170 - 400 mm

- centrifugal force compensation
- proofline® chucks = fully sealed – low maintenance
- 3 jaws, closed center

NT-RC

QUICK JAW CHANGE
Tongue & groove

NT-RD

QUICK JAW CHANGE
serrated master jaws

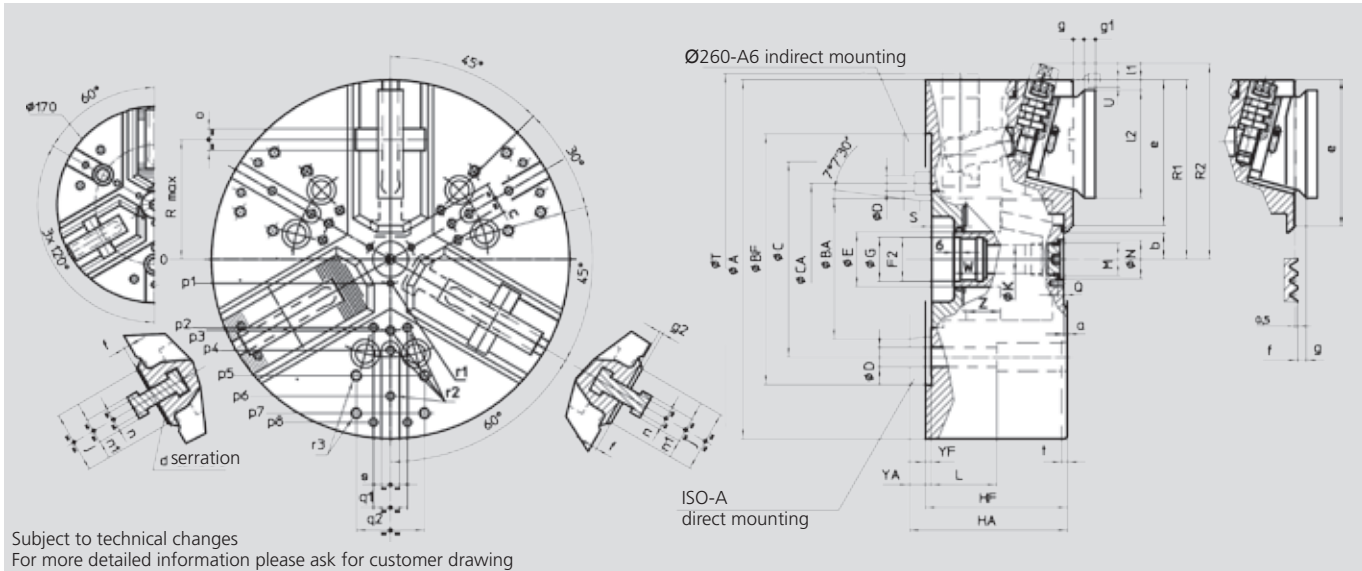

Subject to technical changes
For more detailed information please ask for customer drawing

SMW-AUTOBLOK Type			NT-RD 170 NT-RC 170		NT-RD 215 NT-RC 215		NT-RD 260 NT-RC 260			NT-RD 315 NT-RC 315		NT-RD 400 NT-RC 400	
Mounting			Z140	A5	Z170	A6	Z220	A6	A8	Z220	A8	Z300	A11
	A	mm	172		216		262			315		390	
	Bf/BA	H6 mm	140	82.563	170	106.375	220	106.375	139.719	220	139.719	300	196.869
	C	mm	104.8		133.4		171.4	-	171.4	171.4		235	
	CA	mm	-	-	-	-	-	133.4	-	-	-	-	-
	D	mm	11.5		13.5		17	13.5	17	17		21	
	E	mm	32		42		48			48		75	
	F2	mm	M24 x 2		M32 x 1.5		M38 x 1.5			M38 x 1.5		M60 x 1.5	
	G	H8 mm	25		33		39			39		61	
	Hf/HA	mm	92	102	104	116	118	137	132	125	139	149	164
	K	mm	18.5		20		25			25		48	
	L	mm	43		52		58			58		74	
	M	mm	M22 x 1.5		M22 x 1.5		M28 x 1.5			M28 x 1.5		M52 x 1.5	
	N	H9 mm	24		24		34			34		60	
	Q	mm	5.5		5.5		5.5			5.5		9	
max.	R	mm	56		72		88			105		133.5	
Chuck open	R1	mm	86.5		108		131			157.5		195	
	R2 *	mm	99		122.5		145.5			172		217.5	
max./min.	S	mm	20/3		19/-3		22/-2			20/-10		33/0	
Chuck fully closed	T	mm	175		220		-			-		-	
Radial jaw stroke	U	mm	3.6		4.6		5			6.3		7	
	W	mm	22		26		26			26		38	
	Yf/YA	mm	5	15	5	17	5	24	19	5	19	6	21
max./min.	Z	mm	17/0		22/0		24/0			30/0		33/0	
	a	mm	3		3		3			3		3	
min.	b	mm	8.5		12		14			16.5		31	
min.	c	mm	9		13		14			16		38	
	d	mm	2.5 x 60°		2.5 x 60°		2.5 x 60°			2.5 x 60°		2.5 x 60°	
	e	mm	68		85		106			128.5		150	
	f	mm	5		5		5			5		7	
	g	mm	7.5		7.5		8.5			9.5		11.5	
	g1	mm	8		8		9			10		12	
	g2	mm	3.5		3.5		3.5			3.5		5.5	
	j	mm	30		38		44			54		63	
	l1	mm	2.5		2.5		9			9		8.5	
	l2	mm	52		66		78			95		118	
	n	h8 mm	10		10		12			14		18	
	n1	mm	16		16		19			22		28	
	o	H7 mm	12.68		12.68		19.03			19.03		19.03	
	p1	mm	16		16		21			21		37.5	
	p2	mm	-		-		-			60		80	
	p3	mm	38		49		55			62.5		83	
	p4	mm	-		80		70			80		110	
	p5	mm	65		80		102			102		140	
	p6	mm	70		-		102			120		155	
	p7	mm	-		-		-			135		170	
	p8	mm	-		-		-			-		170	
	q1	mm	-		-		-			30		36	
	q2	mm	36		45		60			60		80	
	r1	mm	M5/7		M5/8		M6/10			M6/10		M6/12	
	r2	mm	M6/14		M8/17		M8/17			M8/17		M10/19	
	r3	mm	M8/17		M8/17		M10/19			M10/19		M12/22	
	s	mm	16		16		16			16		20	
	t	mm	5		5		5			5		5	

*quick jaw change position

AP-R**NT-R****Quick change soft and hard top jaws**

- only for AP-RD, AP-RC, NT-RD, NT-RC
- soft and hard jaws for chucks with serration (2.5 mm x 60°)
- soft jaws for chucks with tongue & groove
- torque wrench for quick jaw change

QUICK JAW CHANGE

QUICK JAW CHANGE

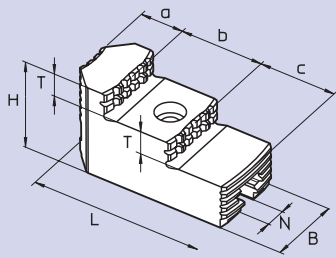
**Hard top jaws with 2.5 x 60° serration for AP-RD and NT-RD chucks**

First operation jaws, if high concentricity is required jaws have to be ground on chuck.

Chuck Ø	Id. No.*	Serration mm	B mm	H mm	L mm	N mm	T mm	a mm	b mm	c mm	Weight kg/each
170	18081736	2.5 x 60°	30	45	65	10	10	23	24	18	0.36
215	18082136	2.5 x 60°	35	46	82	10	10.5	24	36	22	0.57
260	18082636	2.5 x 60°	45	56	100	12	14.5	27	39	34	1.04
315	18083136	2.5 x 60°	45	57	105	14	14	27	42	36	1.09
400	18084036	2.5 x 60°	55	73	140	18	18.5	42	49	49	2.27

* the number refers to a set of 3 jaws

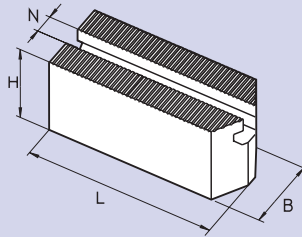
**Soft top jaws with 2.5 x 60° serration for AP-RD and NT-RD chucks**

Chuck Ø	Id. No.	Serration mm	B mm	H mm	L mm	N mm	Weight kg/each
170	18071730	2.5 x 60°	30	40	70	10	0.48
215	18072130	2.5 x 60°	35	45	90	10	0.87
260	18072630	2.5 x 60°	45	60	100	12	1.70
315	18073130	2.5 x 60°	45	60	120	14	2.05
400	18074030	2.5 x 60°	55	75	140	18	3.87

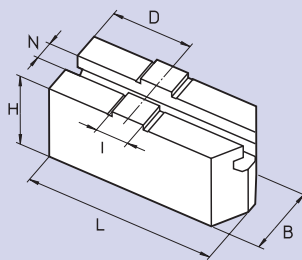
**Soft top jaws with tongue & groove "C" for AP-RC and NT-RC chucks**

Chuck Ø	Id. No.	B mm	H mm	L mm	N mm	D mm	I mm	Weight kg/each
170	18041730	30	37	80	10	30	12.70	0.52
215	18042130	35	44	100	10	35	12.70	0.97
260	18042630	45	57	120	12	42	19.03	2.02
315	18043130	45	57	140	14	50	19.03	2.30
400	18044030	55	70	165	18	60	19.03	4.20

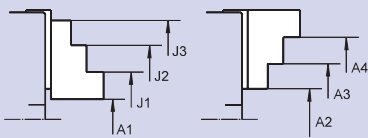
Gripping ranges using standard hard top jaws on AP-RD and NT-RD chucks

Chuck Ø	Id. No.	A1 mm	A2 mm	A3 mm	A4 mm	J1 mm	J2 mm	J3 mm
170	18081736	15-75	-	55-115	105-155	65-120	110-170	145-205
215	18082136	20-95	-	65-145	140-200	75-150	140-215	185-260
260	18082636	20-105	-	95-175	170-245	80-160	150-235	220-305
315	18083136	35-130	-	105-205	190-290	110-195	190-280	265-350
400	18084036	45-170	-	145-275	245-370	135-255	230-350	325-450

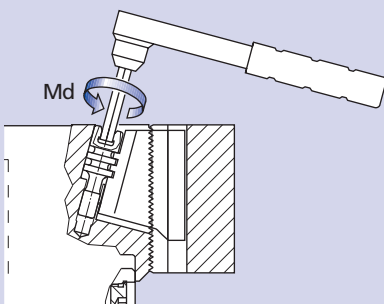
Quick jaw change wrenches

- normal "T" wrenches
- torque wrenches for correct tightening of the quick jaw change bolt

Chuck Ø	Hexagon mm	Correct torque Md N-m	"T" wrench Id. No.
170	6	23	51500812
215	8	45	51500816
260	10	70	51500820
315	12	110	51500822
400	14	200	51500824

Special grease for fully sealed chucks

- resistant against high surface pressure
- for long lubrication intervals
- for proofline® chucks

K67®

Special grease for sealed chucks

K67®

Special for fully sealed chucks included in proofline® series



Cartridge 14 Oz. (DIN 1284)
Net weight: 500 g
Id. No. 10731223



Can 1000 g
Id. No. 10731224

Important for maintenance and safe operation, to be ordered with the chuck

- For sealed chucks with constant grease lubrication
- Basic components: mineral oils and lithium
- Without solvents

Greasing set

Id. No. 083726

Grease gun (DIN 1283) for cartridges 14 Oz. (DIN 1284).

- also refillable from grease can 1000 g

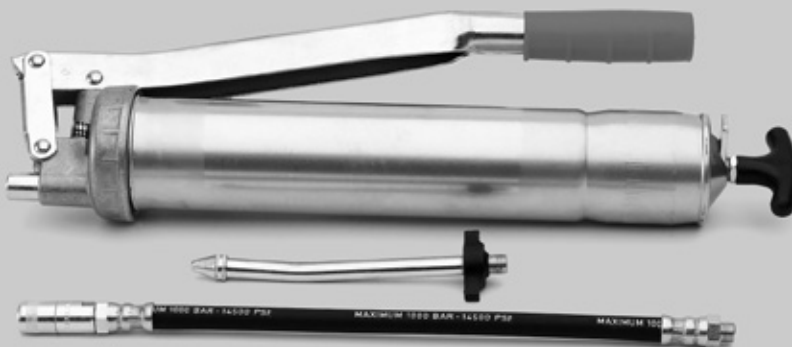

Supply range:

- Grease gun
- 1 adapter flexible for high pressure grease nipple
- 1 adapter for cone grease fitting