

IEP-D

2+2+2 movement
MODULE 2 serrations

High precision 6 jaw chucks 2+2+2 equalising Ø 1000 - 1600 mm

- closed center
- Equalising mechanism lockable



Application/customer benefits

- Clamping of thin walled workpieces
- Low radial deformation with 2+2+2 clamping
- Suitable for horizontal and vertical machines

Technical features

- Adjustable to 6 jaw 2+2+2 or true 6 jaw clamping
- Possibility to regulate the equalizing stroke from full for OP10 to very small for OP20
- Constant gripping force with permanent lubrication
- Centrifugal compensation for high spindle speed
- **proofline® chucks** = fully sealed – low maintenance

Standard equipment

- chuck with mounting bolts
- 1 set of soft top jaws
- 1 equalizing stroke regulating key

Ordering example

IEP-D 1250/Z520

Actual gripping force diagram

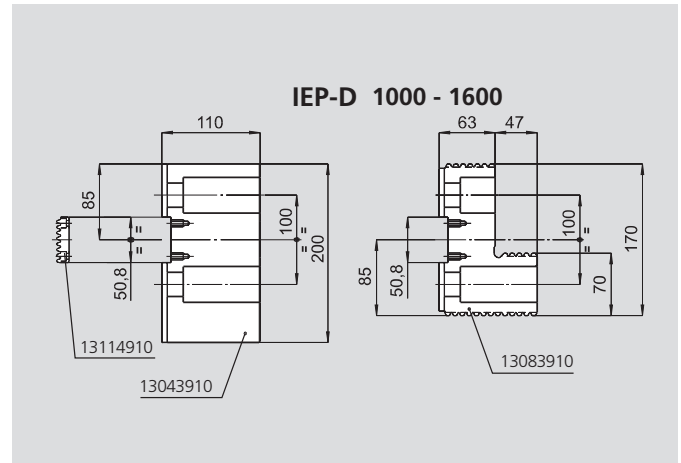
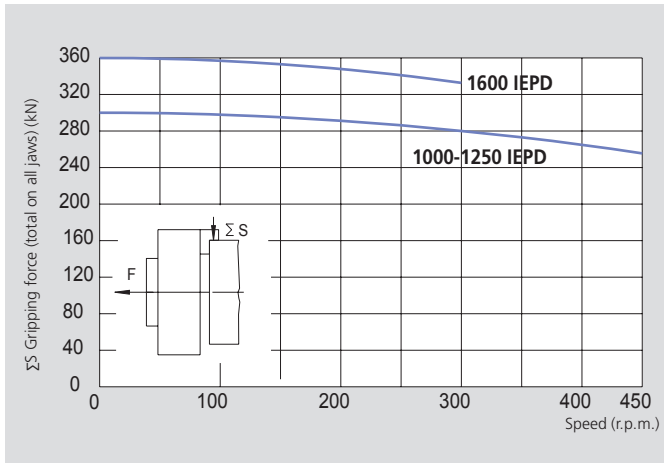

The data in the diagram refer to 6-jaw-chucks, newly maintained according to their service manuals using SMW-AUTOBLOK K67 grease. The static and dynamic gripping forces have been measured using standard soft top jaws, placed in a position not exceeding the outer diameter of the chuck.

⚠ Safety advice/danger of damage:

When using taller/heavier jaws and/or clamping on a bigger diameter reduce draw pull/rotating speed accordingly.

Technical data

SMW-AUTOBLOK Type		IEP-D 1000 2+2+2	IEP-D 1250 2+2+2	IEP-D 1600 2+2+2
Number of jaws				
Radial jaw stroke	mm	20	20	25
Jaw compensation	mm	±5	±5	±5
Axial piston stroke	mm	40	40	50
Max. draw pull*	kN	200	200	240
Max. gripping force*	kN	300	300	360
Max. speed	r.p.m.	450	400	280
Weight (without top jaws)	kg	1080	1500	2370
Moment of inertia	kg·m ²	127	273	640
Hard top jaw (piece)	Id. No.	13083910	13083910	13083910
Soft top jaw (piece)	Id. No.	13043910	13043910	13043910
Recommended actuating cylinders		SIN-S 200-250	SIN-S 200-250	SIN-S 200-250

* For internal clamping reduce the draw pull by 30 %

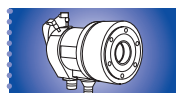

High precision 6 jaw chucks 2+2+2 equalising Ø 1000 - 1600 mm

- closed center
- Equalising mechanism lockable

IEP-D

2+2+2 movement
MODULE 2 serrations

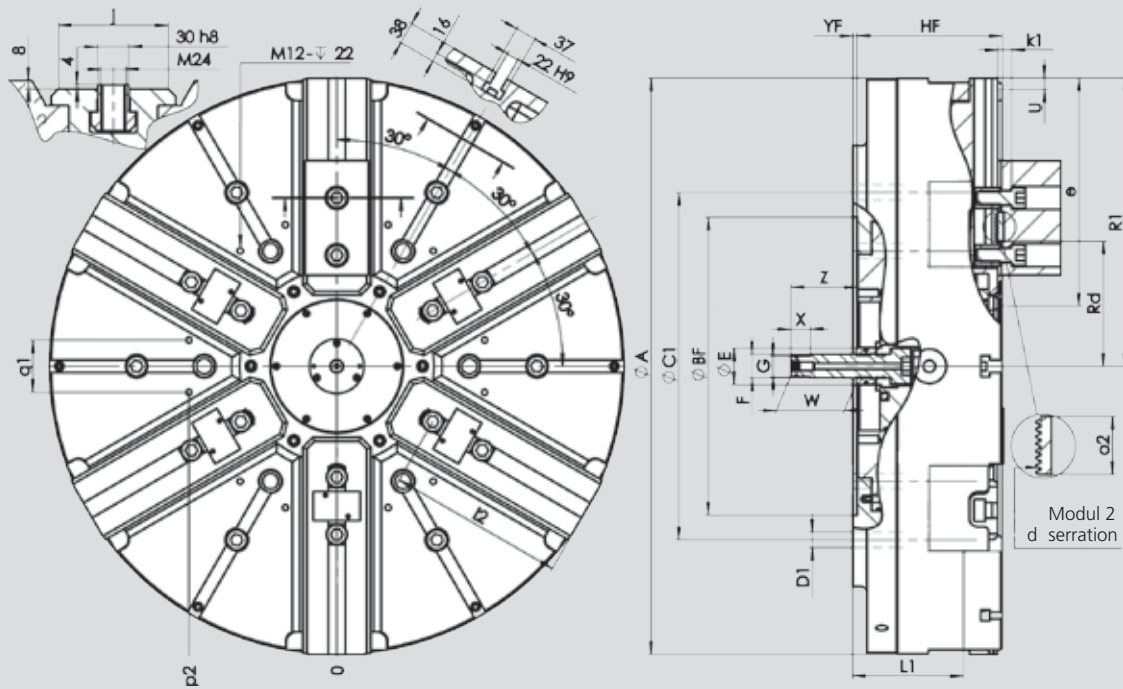

Subject to technical changes
For more detailed information please ask for customer drawing

SMW-AUTOBLOK Type			IEP-D 1000		IEP-D 1250		IEP-D 1600	
	A	mm	1005		1250		1600	
	BF	H6 mm	520		520		720	
	C	mm	463.6		463.6		647.6	
	C1	mm	700		700		1110	
	D	mm	27		27		33	
	D1	mm	27		27		27	
	E	mm	64		64		64	
	F	mm	M42 x 3		M42 x 3		M42 x 3	
	G	H8 mm	36		36		36	
	HF	mm	254		254		272	
	L	mm	186		186		225	
	L1	mm	194		194		233	
Chuck open	R1	mm	498		620.5		798.5	
Chuck open	Rd	mm	228		228		288.5	
Jaw stroke	U	mm	20		20		25	
	W	mm	114		114		114	
	X	mm	34		34		34	
	YF	mm	8		8		8	
max./min.	Z	mm	156	116	156	116	156	106
serration	d	M	Module 2		Module 2		Module 2	
	e	mm	345		465		595	
	j	mm	105		105		131	
	k1	mm	24		24		24	
max./min.	l2	mm	295	118	417	118	531	118
	o2	mm	50.8		50.8		50.8	
	p2	mm	258.5		258.5		*	
	q1	mm	91		91		*	

* please ask for a chuck drawing