

- hydraulic clamping and indexing
- 2 jaws
- Divisions: 4 x 90°/8 x 45°/3 x 120°/6 x 60° or specials

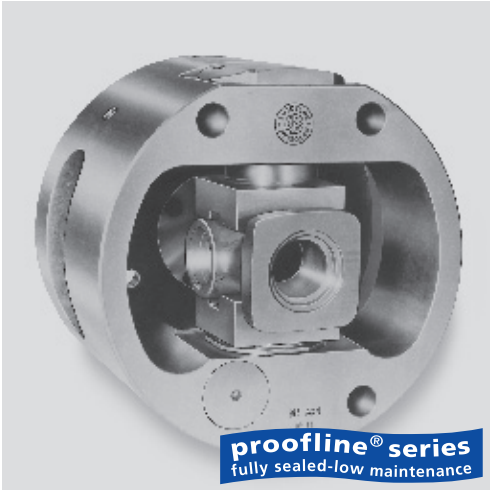

Application/customer benefits

- Fully automated and high productivity machining of components with orthogonal axis or with 45°, 60° or 120° axis
- High productivity for machining of workpieces like valve bodies, spiders or fittings (see picture below) at high position accuracy.

AXN: Automatic indexing chuck with hydraulic clamping and indexing

Technical features

- Rigid holding of the workpiece at high revolutions allowing high chip removal rates
- High positioning and repeatability precision
- Reliable indexing system with constant oil lubricated internal mechanism
- Constant and automatic in-process controls for extremely safe machining
- **proofline® chucks** = fully sealed – low maintenance

Components supplied on request

Adapter parts and clamping jaws

Unique features

- Hardened and ground body, designed to avoid deformation, ensuring rigidity and accuracy
- Easy installation to the machine
- Indexing movement during spindle rotation, allowing a quick change between the multiple working axes
- Indexing and clamping mechanism constantly oil lubricated and supported by strong systems of roller bearings
- Very high maximum speed, with centrifugal force compensation system, for higher productivity performance
- Very simple hydraulic system based on just 4 hoses, 2 for the indexing mechanism and 2 for the clamping piston
- Internal mechanisms fully protected against contamination by coolant, chips and dust
- Constant and automatic control of the position of the part and other working parameters by the C.N.C. of the machine, or by a separate electronic interface



General operating diagram

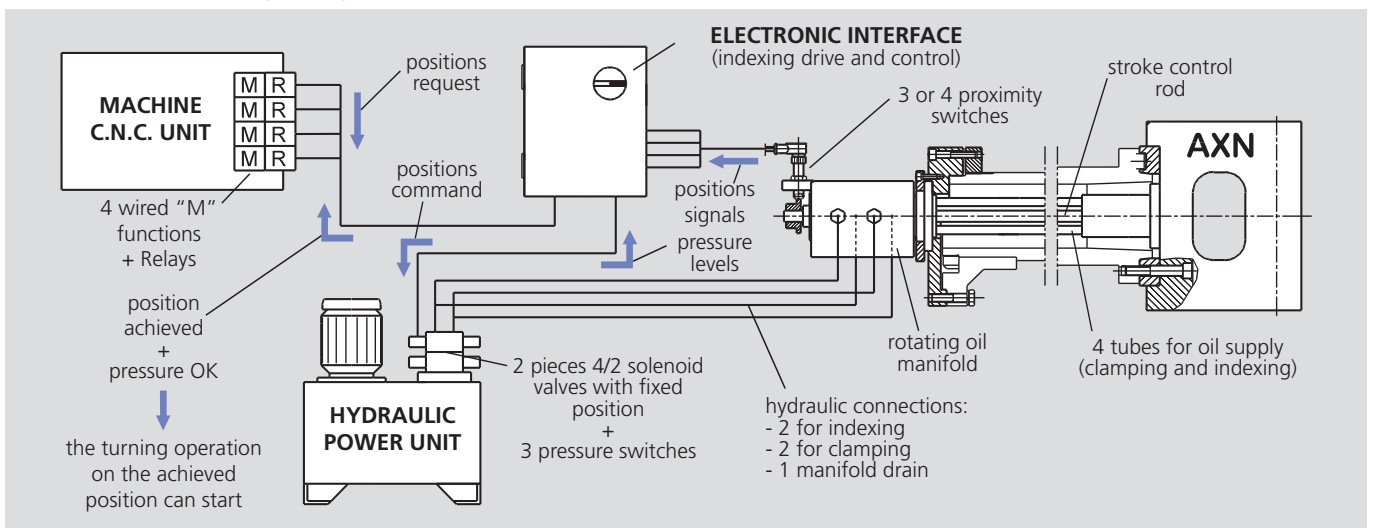

- hydraulic clamping and indexing
- 2 jaws
- Divisions: 4 x 90°/8 x 45°/3 x 120°/6 x 60° or specials

Unique indexing system

- Extremely simple and rigid indexing system
- On the indexing shaft there is a triangle, square or multiple face shape. The indexing shaft "A" is rotated by the piston "C" and is locked in position by the piston "B".
- For clamping and indexing 4 hydraulic lines are needed.

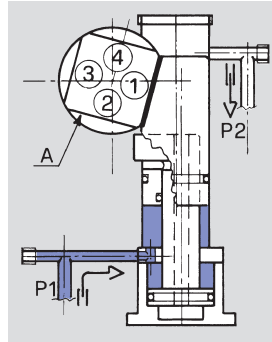

Fig. 1 - Pressure in P1
Indexing shaft A locked in position 1 by the locator B: turning operation on the first side of the component

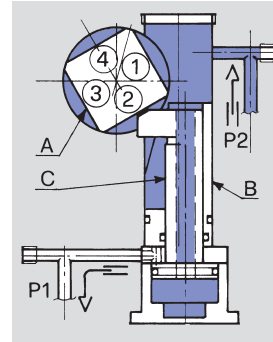

Fig. 2 - Pressure in P2 (indexing)
The locator B retracts and releases the indexing shaft A; the finger C moves forward and rotates the shaft by 45°

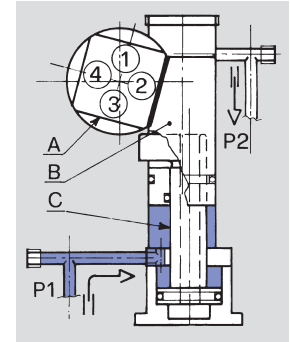
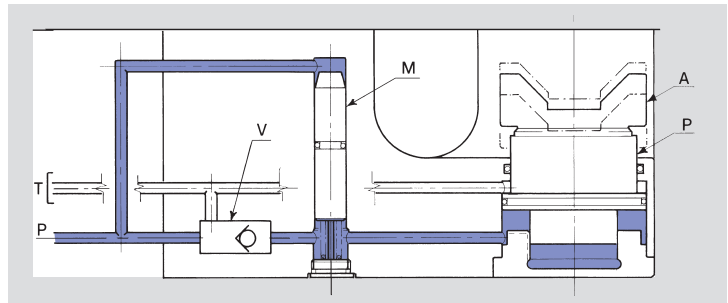

Fig. 3 - Pressure in P1
The finger C retracts, while the locator B moves forward rotating the shaft A to 90° and locking it in position 2 for machining of the work-piece

Centrifugal force compensation system

- Unique hydraulic system designed to reduce the loss of gripping force caused by the centrifugal force on the clamping piston P and clamping jaw A.
- The counterweight M is in a radial hole in the chuck body connected to the hydraulic circuit through the non-return valve V.
- During rotation, the pressure created by the counterweight M increases the pressure on the clamping piston P and compensates for the loss of gripping force due to the centrifugal force.



Indexing position control system

- The indexing control is mounted on the oil manifold. It is actuated by a rod system and monitored by 4 proximity switches.
- The cam "E" on the indexing jaw moves the rear switch ring "N" via the rod "F", lever "H", rod "G" and pullback spring "M".
- The corresponding proximity switch for each indexing position is actuated by the switch ring "M" and confirms, that the indexing position is being reached.

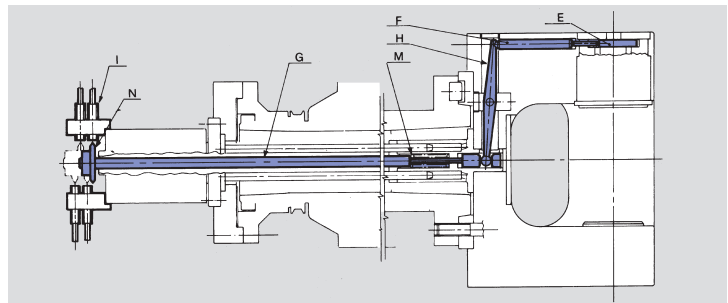

Interchangeability between AXN indexing chuck and front end power chuck HYD-S

The AXN chuck can easily and quickly be changed with a front end power chuck with 3 or 4 jaws type HYD-S. The oil manifold and the tube bundle remain mounted on the machine to actuate the chuck.

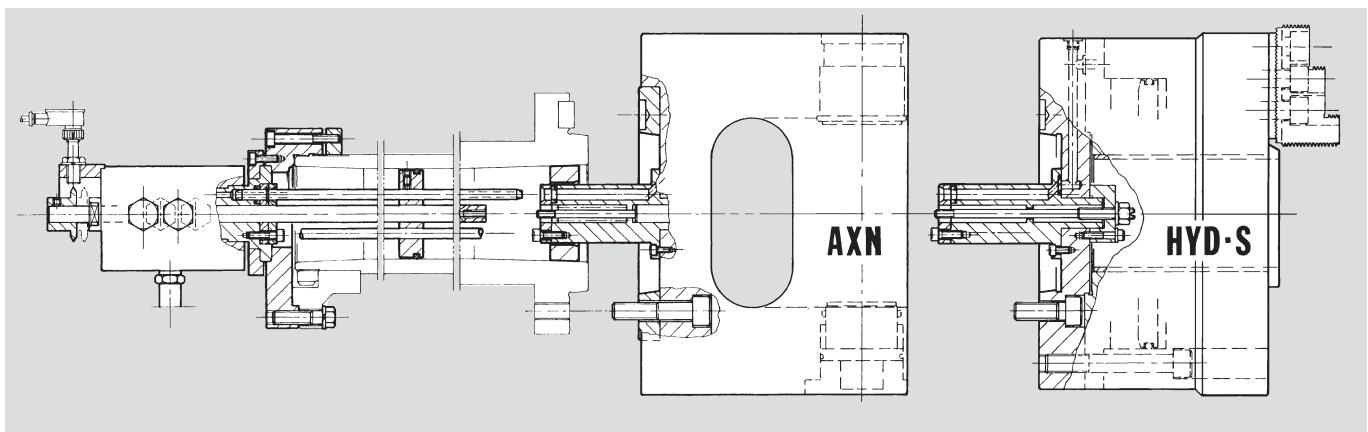

Which is the right indexing chuck diameter for my parts?

- The complete line of AXN indexing chucks has been designed to clamp and index almost all kind of multi axis parts that are possible to find on the market
- The important dimensions to check in the following drawing and table are:
 - **G** diameter > the biggest diagonal of the component
 - **T** dimension + indexing jaw room (jaw mounted on the indexing shaft) > 1/2 of the height of the component
- Another way to check if the part can be indexed on a specific chuck, is to make a simple drawing showing the part clamped in center by the clamping jaws and its 360° rotation around the indexing axis inside of the internal pocket of the chuck
- Besides the workpiece dimensions also parameters as the clamping force, the stroke of the clamping piston, the overhang of the component from the chuck face sufficient tool clearance and the working cycle, are relevant

Attention: The requested AXN chucksize is not only determined by the size and weight of the component, but also by the production process. Therefore the determination of the AXN-chucksize must be done in accordance with SMW-AUTOBLOK

The experienced SMW-AUTOBLOK technicians can help you in all steps of this decision process: don't hesitate to contact them!

Highest accuracy is achieved if finishing operation is done at same spindle speed (constant r.p.m.).

Dimensions

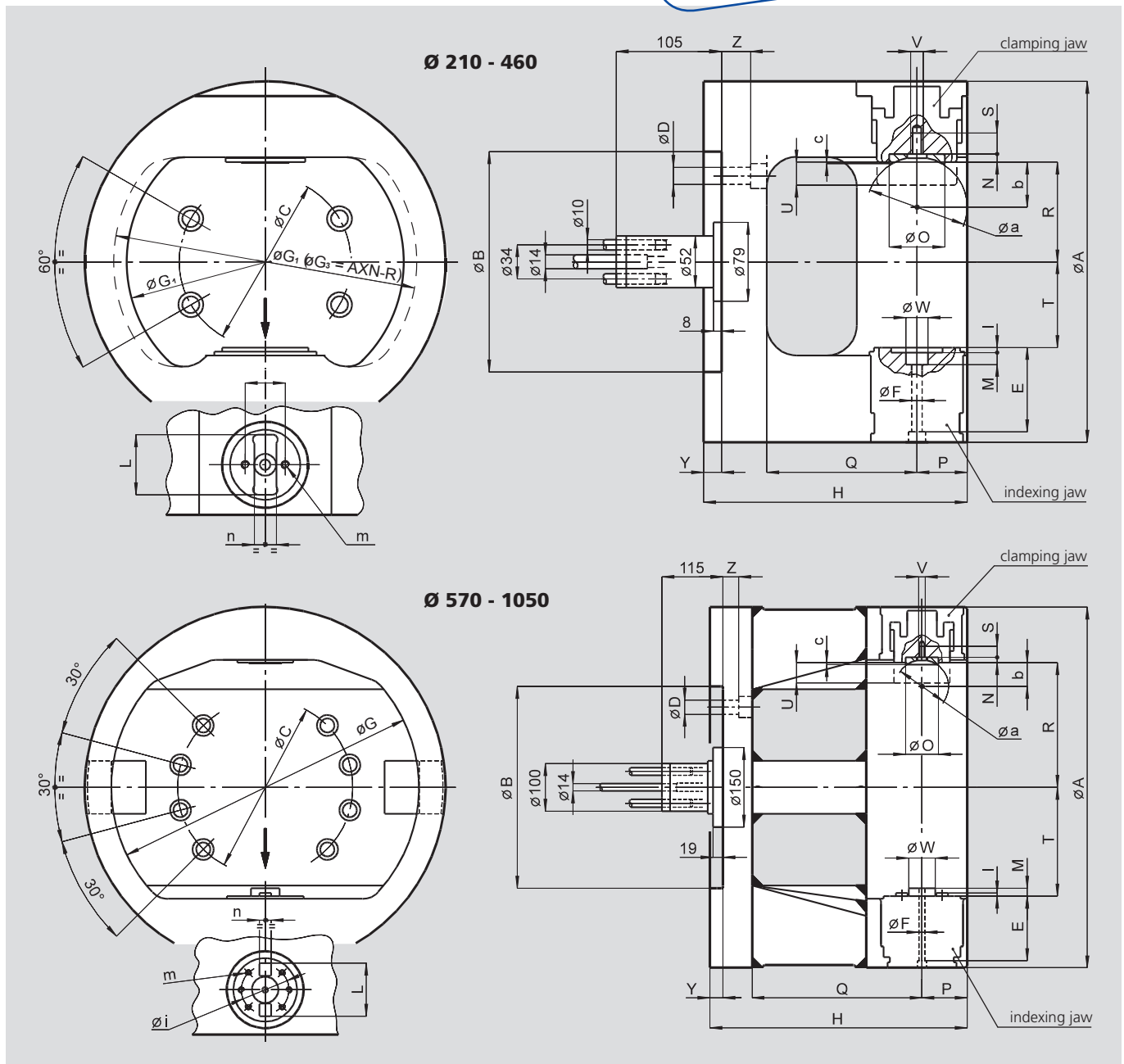

AXN Automatic indexing chucks Ø 210 - 1050 mm

■ Divisions: 4 x 90°/8 x 45°/3 x 120°/6 x 60° or specials

AXN®

Automatic indexing chuck standard body

AXN®-R

Automatic indexing chuck with reinforced body

AXN-R Automatic indexing chucks, reinforced Ø 210 - 315 mm

■ Divisions: 4 x 90°/8 x 45°/3 x 120°/6 x 60° or specials

ISO-A flanges for AXN chucks

Type 1 - direct ISO-A mounting	Type 2 - reduction ISO-A mounting	Type 3 - increase ISO-A mounting	AXN chuck size	Spindle	Type	Id. No.	A	Bf	BA	C	C1	T
			210-235	A5	2	24552030	-	170	82.563	104.8	133.4	24
			210-235	A6	1	24162500	-	170	106.375	133.4	-	24
			254-280-315-360	A6	2	24562530	-	220	106.375	133.4	171.4	24
			205-235	A8	3	24182030	210	170	139.719	171.4	133.4	40
			254-280-315-360	A8	1	24182500	-	220	139.719	171.4	-	19
			400-460	A8	2	24183100	-	300	139.719	171.4	235	30
			254-280-315-360	A11	3	24112530	280	220	196.869	235	171.2	50
			400-460	A11	1	24113100	-	300	196.869	235	-	21
			570-680	A11	2	24115000	-	380	196.869	235	330.2	40
			570-680	A15	1	24127100	-	380	285.775	330.2	-	33
			850-1050	A15	2	24126100	-	520	285.775	330.2	463.6	40
			850-1050	A20	1	24178000	-	520	412.775	463.6	-	25

Main dimensions and technical data

SMW-AUTOBLOK dimension AXN		210	235	254	280	315	360	400	460	570	680	850	1050
A	mm	210	235	254	280	315	360	400	460	570	680	850	1050
B	mm	170	170	220	220	220	220	300	300	380	380	520	520
C	mm	133.4	133.4	171.4	171.4	171.4	171.4	235	235	330.2	330.2	463.6	463.6
D	mm	13	13	17	17	17	17	21	21	27	27	27	27
E	mm	70	70	73	73	84	84	99	99	122	122	142	160
F	mm	5.5	5.5	8.5	8.5	10.5	10.5	10.5	10.5	11	11	11	17
Max. workpiece rotation dia.	G	mm	184	206	228	250	275	315	350	410	490	600	750
Max. axial loading window	G1	mm	175	197	216	240	261	301	333	394	466	576	730
Max. workpiece rotation dia.	G2	mm	160	180	195	210	245	-	-	-	-	-	-
Max. axial loading window	G3	mm	150	170	183	198	230	-	-	-	-	-	-
H	mm	187	194	214	227	252	266	293	323	442	492	570	680
I	mm	4	4	5	5	5	5	5	5	6	6	6	10
L	mm	42	42	45	45	60	60	70	70	100	100	100	154
M	mm	9	9	11	11	12	12	12	12	15	15	15	18
N	mm	3	3	6	6	7	7	10	10	10	10	10	10
O	mm	22	22	36	36	48	48	62	62	62	62	62	70
P	mm	36	36	42	42	53	53	60	60	92	92	95	130
Q	mm	95	102	112	125	136	150	170	200	270	320	385	460
max.	R	mm	41.9	54.5	57	70	77	99.5	110	140	180	235	305
S	mm	12	12	14	14	18	18	18	18	19	19	19	22
T	mm	30	42.5	45	58	63	85.5	91	121	150	205	270	310
Clamping jaw stroke	U	mm	15	15	17	17	23	23	30	30	40	40	55
V	mm	M6	M6	M8	M8	M10	M10	M10	M10	M10	M10	M10	M12
W H6	mm	12	12	18	18	22	22	22	22	50	50	50	55
Y	mm	16	16	16	16	18	18	18	18	25	25	25	25
Z	mm	28	28	32	32	29	29	24	24	50	50	60	70
a	mm	40	40	60	60	100	100	100	100	100	100	100	110
b	mm	17.5	17.5	26	26	45	45	42	42	42	42	42	47
c	mm	0.5	0.5	0.5	0.5	0.5	0.5	1	1	1	1	1	3
i	mm	28	28	35	35	40	40	40	40	90	90	90	130
m	mm	M5	M5	M6	M6	M8	M8	M8	M8	M10	M10	M10	10 x M12
n H6	mm	12	12	18	18	22	22	22	22	22	22	22	22
Clamping piston area	cm ²	30	30	43	43	63.6	63.6	86.6	86.6	113	113	132	227
Max pressure	bar	45	45	45	45	45	45	45	45	45	45	45	45
Max. speed (1)	r.p.m.	4400	3800	3600	3400	2800	2400	2200	1800	1200	1000	700	500
Moment of inertia	kg·m ²	0.17	0.27	0.45	0.69	1.27	2.15	3.4	6.4	20	39	106	290
Clamping top jaw weight (1)	kg	0.6	0.6	1.3	1.3	2	2	4	5	6	7	9	15
Weight	kg	28	32	47	57	82	104	137	182	370	520	890	1600

(1) IMPORTANT:

- Max rotation speed can be reached only at max. operating pressure and using a clamping jaw with a mass not exceeding the value shown in the above schedule.
- The component to be machined and the two clamping jaws must always be perfectly balanced around the axis of rotation, when this is not possible, or the clamping jaw is heavier, the rotation speed must be correspondingly reduced.
- The component may be indexed during rotation; when working at high r.p.m., it is advisable to reduce speed 30-50% during the indexing operation to avoid vibrations due to the unbalance of masses while the part is in an intermediate position.