

SF-RAZ

Tongue & groove

2 Position hydraulic ring indexing chuck

- 3 self centering and 3 compensating jaws
- large evacuation windows for easy chip flow
- fully automatic and controlled indexing
- hydraulic actuation

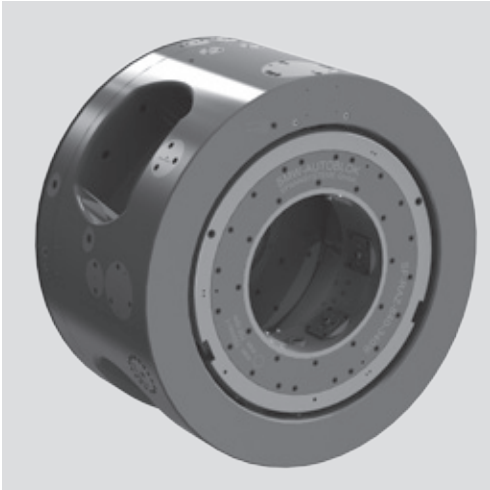

Application/customer benefits

- Machining of couplings in one set up
- Indexing 180° in 2 seconds
- 6 jaw clamping for perfect roundness of the coupling = ideal for premium threads
- High-Low clamping (roughing-finishing)

Technical features

- Hydraulic, automatic ring indexing chuck
- All functions controlled by proximity switches
- Extremely accurate and rigid indexing mechanism
- For external clamping only
- Automatic central lubrication

Standard equipment

Chuck with mounting bolts

Ordering example

SF-RAZ 950-3+3 A 20

Accessories

Hydraulic manifold including electric manifold, hose kit

Machining of a coupling in 1 set up:

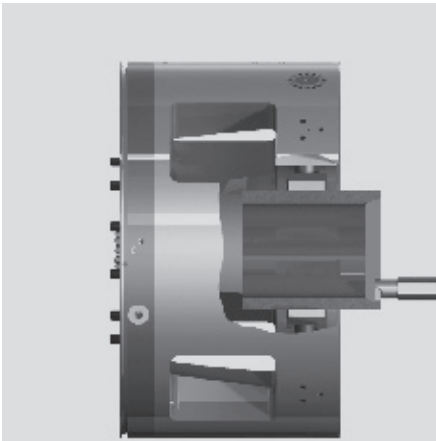

Fig. 1

Clamping the coupling on the outside diameter with 6 jaws (3 self centering and 3 compensating jaws) and machining the thread on side 1.

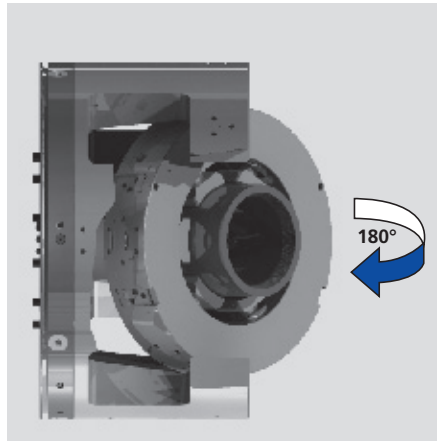

Fig. 2

Indexing the chuck 180° with the coupling remaining clamped.

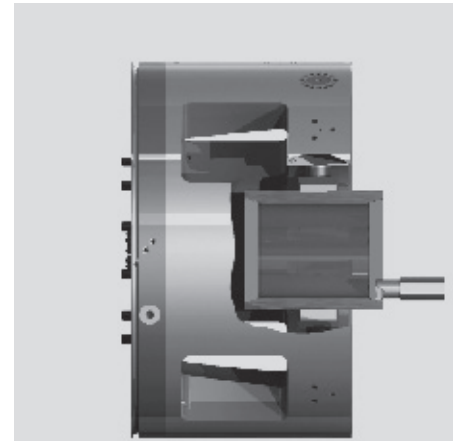

Fig. 3

After indexing 180°, machining the thread on side 2.

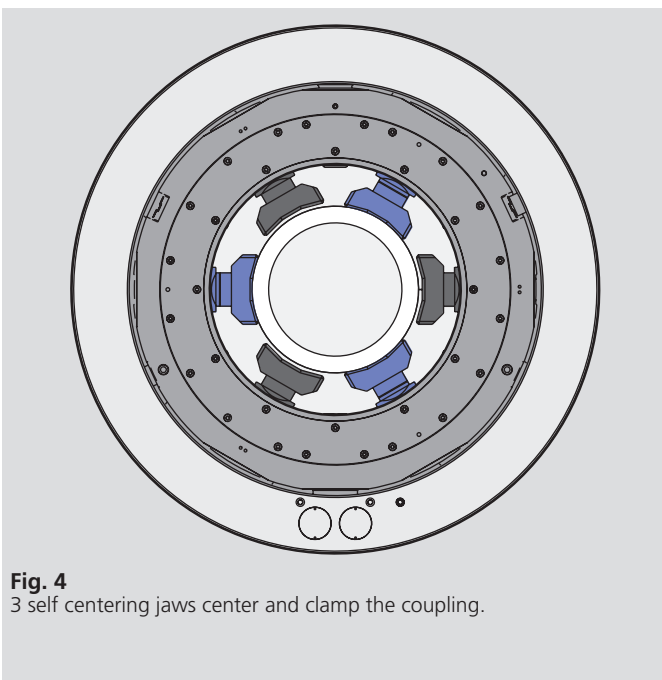

Fig. 4

3 self centering jaws center and clamp the coupling.

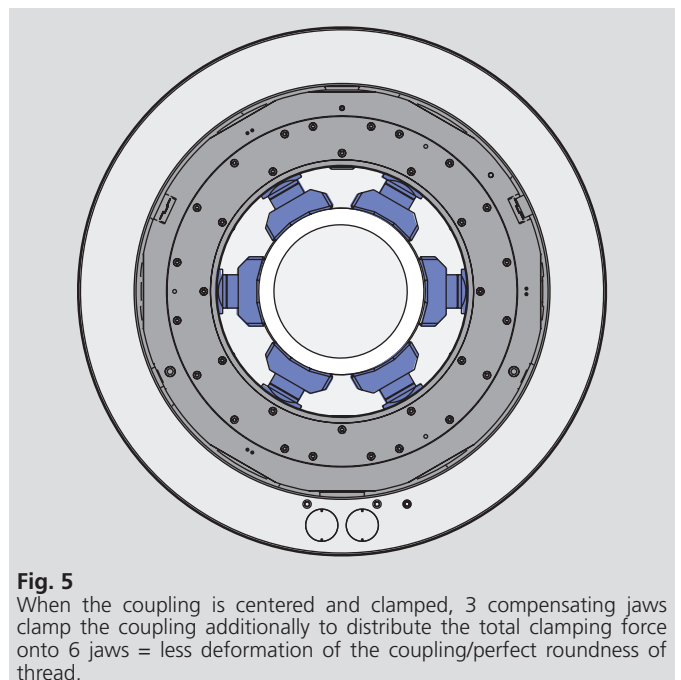

Fig. 5

When the coupling is centered and clamped, 3 compensating jaws clamp the coupling additionally to distribute the total clamping force onto 6 jaws = less deformation of the coupling/perfect roundness of thread.

Main dimensions and technical data

Tongue & groove

Data sheet shows no jaw dimensions and radial covers for switches and adjustments
Data sheet shows only general dimensions!

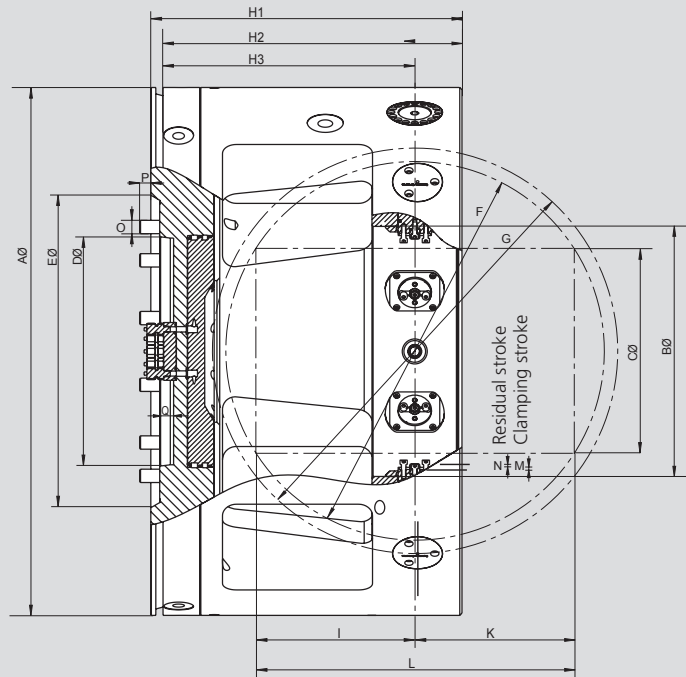
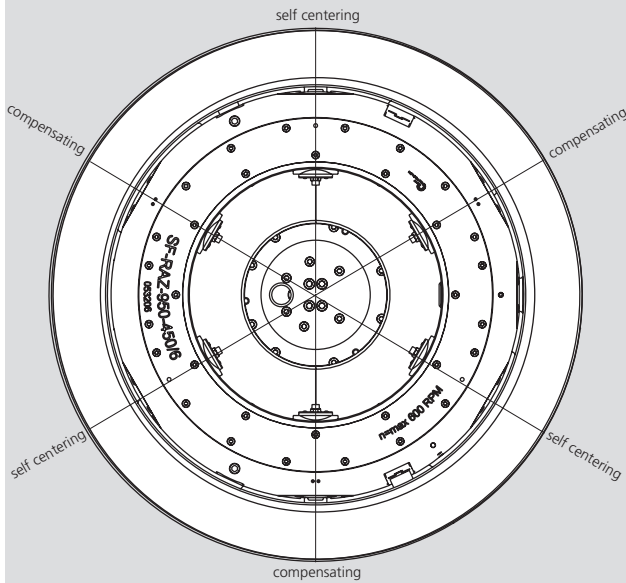

Subject to technical changes
For more detailed information please ask for customer drawing

SMW-AUTOBLOK Type			SF-RAZ 750	SF-RAZ 840	SF-RAZ 950	SF-RAZ 1050
Id. No.			053090	053097	053206	053900
Chuck O.D.	A	mm	750	840	950	1050
Indexing ring I.D.	B	mm	250	340	450	550
Max. workpiece O.D.	C	mm	185	275	368	468
Spindle mounting	D		A15	A15	A20	A20
Recess for spindle O.D.	E	mm	435	435	562	562
Max. swing workpiece	F	mm	480	570	680	780
Swing indexing ring	G	mm	526	618	728	828
	H1	mm	456	501	560	610
	H2	mm	440	485	544	594
	H3	mm	355	400	459	509
	I	mm	221.5	250	286	312
	K	mm	221.5	250	286	312
Max. length of workpiece	L	mm	443	500	572	624
Clamping at rec. clamping stroke	M	mm	5.5	5.5	5.5	5.5
Recom. residual stroke	N	mm	4.5	4.5	4.5	4.5
Total jaw stroke	S	mm	10	10	10	10
Mounting bolts	O	mm	M24	M24	M24	M24
	P	mm	37	37	36	36
Max. speed		r.p.m.	800	700	600	530
Max. pressure		bar	70	70	70	70
Max. grip force		kN	250	250	250	250
Weight		kg	1018	1200	1650	2155

Installation of SF-RAZ with hydraulic manifold, electric manifold and hose kit: (All these accessories must be ordered separately)

