

- oil feed through spindle wall
- 3 jaws

LONG STROKE  
INCH serration



### Application/customer benefits

- Machining of bars/shafts
- For special applications / special machines / rotary tables
- Complete spindle bore can be used

**HYDL-S:** long stroke INCH serration 3/32" x 90°

### Technical features

- Power chuck with big through hole, wedge hook design
- Built in cylinder with safty valves
- Chuck body case hardened
- Special mounting dimensions on request

### Standard equipment

- 3 jaw chuck
- 1 set T-nuts with bolts
- 1 set of top jaws
- Mounting bolts
- Grease gun

### Ordering example

3 jaw chuck HYDL-S 500 A11

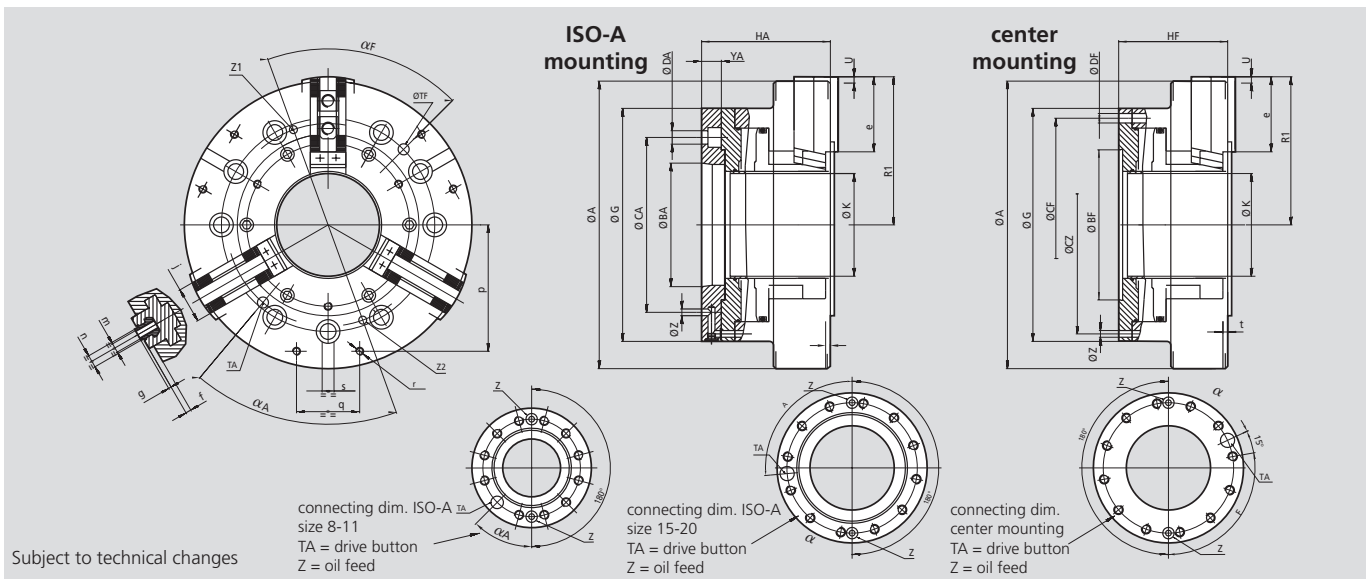

### Technical data

SMW-AUTOBLOK Type		HYDL-S 500	HYDL-S 630	HYDL-S 800
Radial jaw stroke	mm	11	13.5	13.5
Max. pressure	bar	30	25	25
Max. gripping force	kN	150	250	250
Max. speed	r.p.m.	1600	1300	1000
Moment of inertia	kg·m <sup>2</sup>	5.1	16	48
Weight (without top jaws)	kg	160	310	580

### Dimensions type HYDL-S

Type	A	G	K	R <sub>1</sub> open	U stroke	e	f	g	j	m	n	Z
	mm	mm	mm	mm	mm	mm	mm	mm	mm	mm	mm	mm
HYDL-S 500	500	400	180	256	11	116	9	3.5	62	M20	25.5	10
HYDL-S 630	630	540	250	323	13.5	140	9	3.5	62	M20	25.5	10
HYDL-S 800	800	540	250	405	13.5	165	9	3.5	75	M20	25.5	12

### Dimensions of chucks with center mounting

All types Size	B <sub>F</sub> H6	C <sub>F</sub>	C <sub>Z</sub>	D <sub>F</sub>	H <sub>F</sub>	Y <sub>F</sub>	T <sub>F</sub>	α <sub>F</sub>
	mm	mm	mm	mm	mm	mm	mm	deg.
Ø 500	300	350	330.2	17	185	6	20	65°
Ø 630	380	463.6	463.6	27	210	6	24	65°
Ø 800	380	463.6	463.6	27	220	6	24	65°

### Dimensions of chucks with ISO-A mounting

All types Size	B <sub>A</sub> J4	C <sub>A</sub>	D <sub>A</sub>	H <sub>A</sub>	α <sub>A</sub>	Z <sub>A</sub>
	mm	mm	mm	mm	deg.	mm
Ø 500 A11	196.869	235	21	220	45°	10
Ø 500 A15	285.775	330.2	25	225	85°	12
Ø 630 A15	285.775	330.2	25	250	85°	12
Ø 630 A20	412.775	463.6	27	230	85°	12
Ø 800 A20	412.775	463.6	27	240	85°	12